



Enhancement of shape accuracy and die quenchability of ultra-high strength steel hollow products in hot stamping of tubes using eco-friendly fiber-reinforced ice mandrel

Ali Talebi-Anaraki¹ · Tomoyoshi Maeno² · Yuta Matsubara¹ · Ryohei Ikeda¹ · Ken-ichiro Mori³

Received: 30 December 2022 / Accepted: 23 February 2023
© The Author(s) 2023

Abstract

A hot stamping process of quenchable steel tubes using a mandrel reinforced with eco-friendly fibers was developed to produce ultra-high strength steel hollow parts having enhanced lightweighting and crashworthiness. High internal pressure was generated to improve the die quenchability and shape accuracy of the formed parts by the fiber reinforcement. Wood sawdust, shredded copy paper, and plant fiber made of recycled toilet paper were chosen as the fibers, and not only the strength was evaluated from a uniaxial compression test but also the melting behavior of the mandrel was examined. The influence of the fiber reinforcement on the shape accuracy and die quenchability of hot-stamped parts was investigated. The generated internal pressure with the fiber-reinforced ice mandrel was higher than that with the pure ice mandrel without the reinforcement, and thus, the shape accuracy and die quenchability of hot-stamped parts were significantly improved even for a comparatively small change in internal volume of tubes.

Keywords Hot stamping · Tube forming · Fiber-reinforced composites · Buckling · Rapid cooling · Die quenching

1 Introduction

With the continuous development of the automobile industry, the efforts to reduce the entire weight of automobiles and consequently reduce carbon dioxide emissions by improving energy consumption have become the main goals of the modern automobile industry. The utilization of high specific strength materials such as high strength steel is not only considered in terms of vehicle weight reduction but also ensures crashworthiness and safety due to their high tensile strength. For producing complex ultra-high strength steel products having a tensile strength of about 1500 MPa,

hot stamping is a favorable forming process [1, 2]. In hot stamping, quenchable steel sheets are heated up to above the austenite transformation temperature (around 900 °C) and then simultaneously formed and quenched at a cooling rate of over 30 °C/s to ensure transforming into martensite by holding with dies at the bottom dead center of a press slide [3].

The use of hollow components leads to further lightweighting by eliminating the required overlap margin for joining separated stamped parts as well as improving the structural rigidity and strength of chassis parts such as axle beams due to the continuous welded closed-sectional shape. This, in turn, confirms the necessity for the development of forming processes for high strength steel hollow products. On the other hand, hot stamping of tubular components is restricted by their poor shape accuracy during compression deformation due to their hollow shape, which results in low shape accuracy and cooling for die quenching.

Tube hydroforming is a common manufacturing process to form a metal tube into a complex hollow shape using a simultaneous application of high fluid pressure and axial load [4]. On the other hand, the high fluid pressure is replaced with a passive generated pressure by compression of a fluid-filled tube to prevent the buckling, while the tube

✉ Ali Talebi-Anaraki
talebi-ali-bt@ynu.jp

¹ Department of Mechanical Engineering, Materials Science, and Ocean Engineering, Graduate School of Engineering Science, Yokohama National University, Yokohama 240-8501, Kanagawa, Japan

² Division of Systems Research, Faculty of Engineering, Yokohama National University, Yokohama 240-8501, Kanagawa, Japan

³ Department of Mechanical Engineering, Toyohashi University of Technology, Toyohashi 441-8580, Aichi, Japan

Fig. 1 Hot stamping of tubes: **a** without internal pressure, **b** with ice mandrel, **c** with ice mandrel and insulation sheets, and **d** with fiber-reinforced ice mandrel

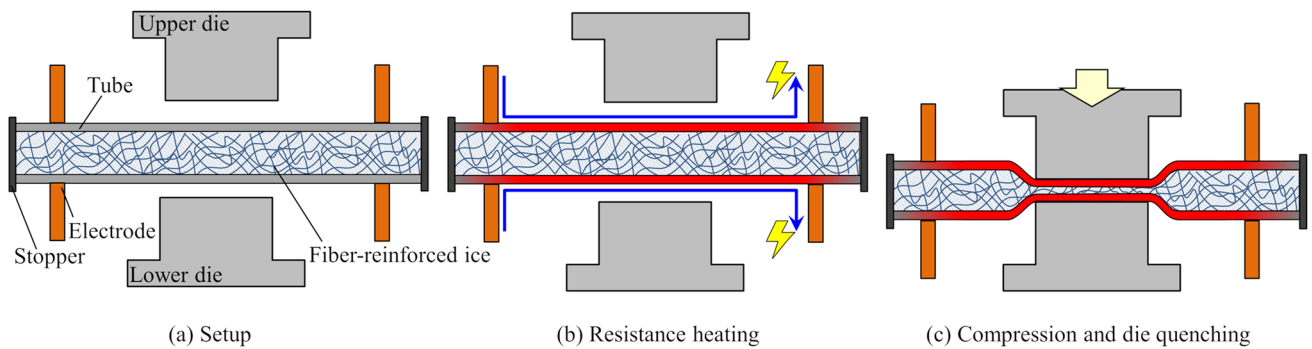
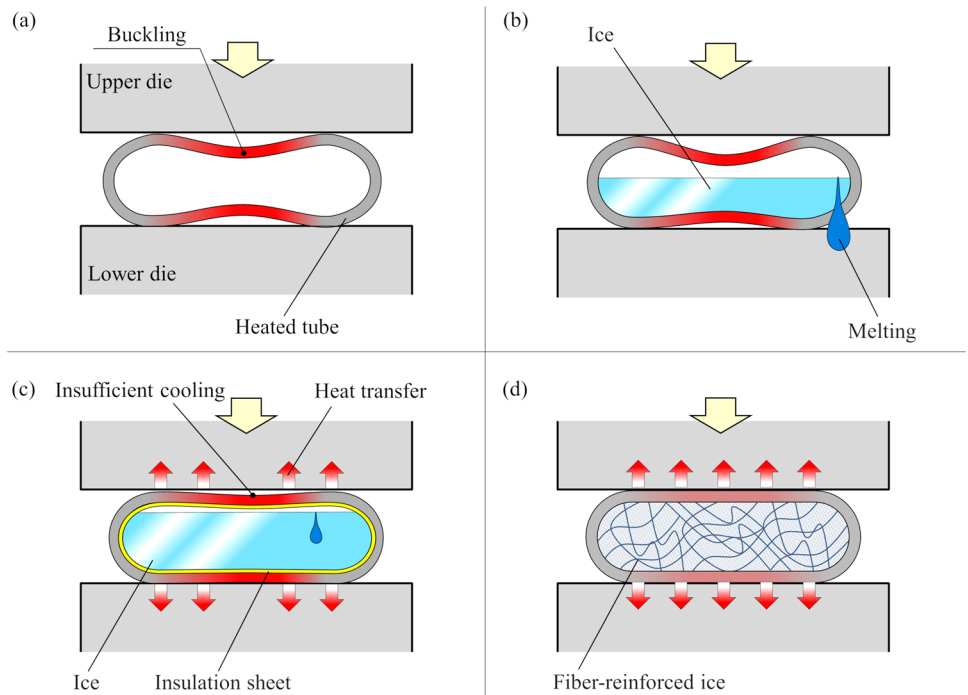
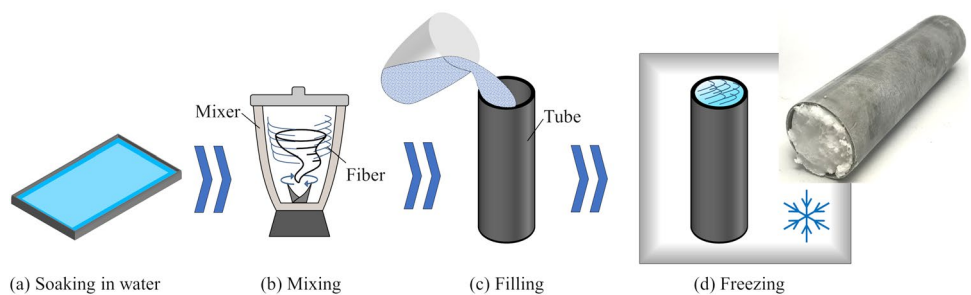

Fig. 2 Sequence of hot stamping of tubes using fiber-reinforced ice mandrel and resistance heating

is mainly formed by closing a moving punch. This leads to a significant reduction of the required internal pressure and die-closing force compared to the high forming pressure [5].

Since heating can remarkably improve the ductility of materials, warm and hot forming processes have been applied to tube forming. However, for temperatures over

Fig. 3 Preparation of fiber-reinforced ice mandrels



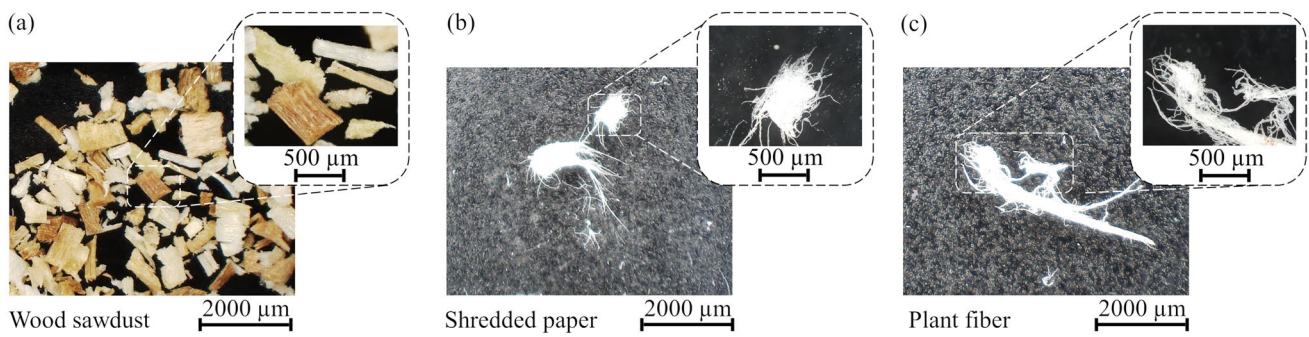

Fig. 4 Microscopic view of utilized fibers for fiber-reinforced ice mandrels

300 °C, fluids are generally not appropriate [6], and utilization of gaseous media has been increasingly developed to provide higher heating temperatures [7, 8]. Although the gaseous media has a significant impact on improving the formability, it is still difficult to sufficiently quench the steel tubes with gas due to the low cooling rate. Neugebauer et al. [9] developed a hot tube gas forming setup by increasing the compressed gas pressure up to 70 MPa. To ensure sufficient quenchability, high internal gas pressures for attaining complete contact with forming tools are necessary, and thus, the energy for compressing the gas is high, and the equipment becomes costly. Talebi-Anaraki et al. [10] proposed a sealed

air gas forming process for producing ultra-high strength bulged hollow parts under an initial sealed pressure of less than 3 MPa. However, it is still difficult to form small corner radii with sealed air.

Heat-resistant shapeless solids such as ceramic powders and sands can be utilized as the alternative forming medium to provide required pressure with short pressure build-up times and more safety compared with gas media [11, 12]. Grüner and Merklein [13] confirmed that the pressure distribution inside the granular media is not hydrostatic and depends on the direction that the media is pressurized. Yang et al. [14] determined that the friction between the tube

Fig. 5 Experimental setup for hot stamping of tubes using fiber-reinforced ice mandrel and resistance heating

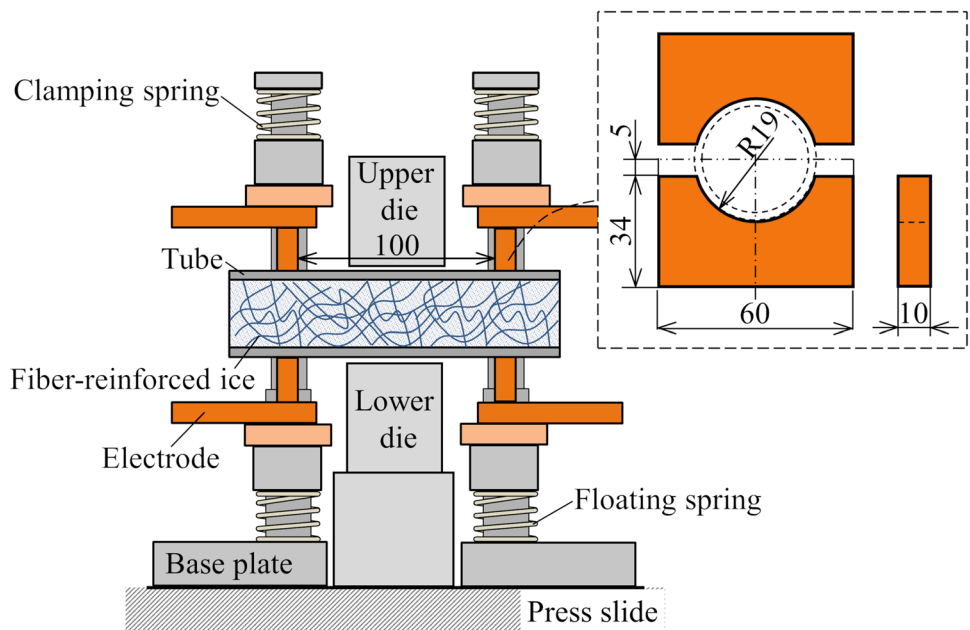

Table 1 Chemical composition of quenchable steel tube [wt%]

C	Si	Mn	P	S	Cr	B
0.187	0.159	1.37	0.0170	0.0040	0.29	0.0039

Table 2 Conditions of hot stamping of tubes using fiber-reinforced ice mandrels

Parameter	Value
Current density [A/mm ²]	30 (5.6 kA)
Heating time [s]	13.5
Distance between electrodes [mm]	100
Holding time at bottom dead center for quenching [s]	10
Total process time [s]	24–25

and granular media has a significant effect on the formed product. Chen et al. [15] utilized high-temperature granular materials for the press hardening of steel tubes. However, the process is still limited due to the non-hydrostatic and frictional properties of the granular medium.

Talebi-Anaraki et al. [16] utilized an ice mandrel in hot stamping of steel tubes not only to prevent buckling but also to improve the quenching behavior. To prevent rapid melting of the pure ice mandrel, thermal insulation sheets were utilized, and the tubes were rapidly resistance-heated. However, the generated pressure by ice depends on the strength of the ice mandrel. Moreover, it is still difficult to obtain full hardening of tubes in low compression ratios without changing the internal volume of tubes by pure ice mandrels. Therefore, it is desirable to increase the strength of pure ice mandrels to further improve the forming accuracy of hot-stamped steel tubes in both high and low compression ratios.

The inclusion of fibers is an effective method for improving the strength characteristics of products. Carbon fibers [17] and glass fibers [18] are widely utilized for the strengthening of plastics and resin products. Since the forming tools are generally costly and the lead time is relatively long, plastic tools have been noticed in manufacturing processes.

However, the strength of plastic tools is still limited, and reinforcing is required for them [19]. Therefore, the utilization of fibers for strengthening the forming tools can be an attractive solution.

This paper aims at utilizing fiber reinforcements to improve the ice characteristics as a forming mandrel in hot stamping of hollow components. First, to study the fiber-reinforced ice properties, the strength and melting behavior of the mandrels were examined. Afterward, the ice mandrels reinforced with natural fibers were employed to investigate the forming behavior and die quenchability of the hot-stamped tubes. The strength of pure ice mandrel was improved by the utilization of natural fibers, and the shape accuracy and die quenching of press-hardened hollow products were significantly enhanced even in low compression ratios.

2 Application of ice mandrels reinforced with natural fibers to improve generated internal pressure in hot stamping of tubes

2.1 Prevention of melting and reinforcement of ice mandrel using natural fibers

In hot forming process of a tubular product by compression, buckling tends to occur due to the inside hollow structure of the tube material, which leads to reduce the shape accuracy as shown in Fig. 1a. Moreover, the strength of the hot-stamped products is gained by performing a rapid cooling by die quenching at the bottom dead center of a press machine which is required a high contact pressure to obtain a sufficient cooling rate; however, die quenching of tubes becomes more difficult due to the low contact pressure of

Fig. 6 Temperature distributions of tubes with and without fiber reinforcements just after the end of resistance heating

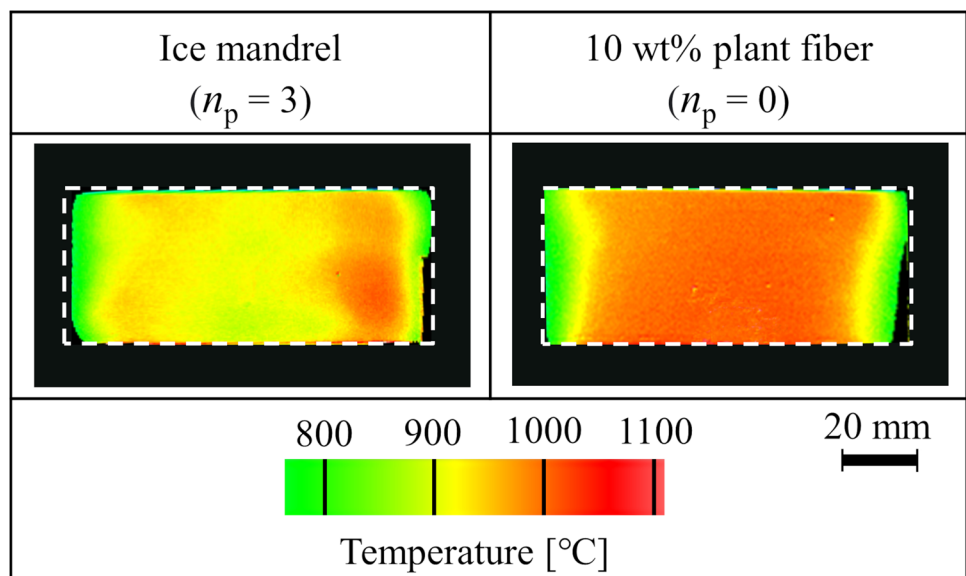
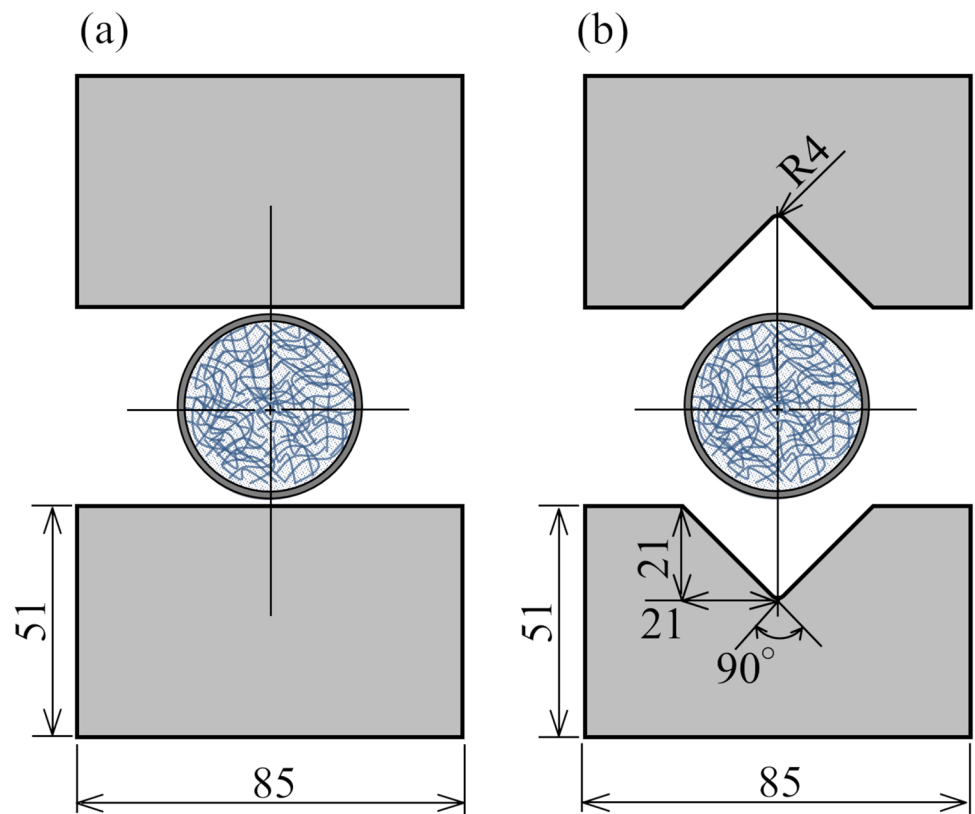

Fig. 7 Dimensions of dies for hot stamping of tubes using fiber-reinforced ice mandrel: **a** high volume compression by flat die and **b** low volume compression by square die



tubes. Therefore, a reaction force from the inside of the tube is required to compensate for the lack of contact pressure and heat transfer rate during hot stamping of hollow products.

Ice is a low-cost natural substance that is environmentally friendly and completely free of risk and waste, which offers a great potential to be employed as a mandrel in tube forming processes as shown in Fig. 1b. However, pure ice is considered a brittle material, and thus, its limited strength and rapid melting especially at elevated temperatures act

as the most challenging obstacles in their applications for obtaining enough die quenching. Therefore, as it is shown in Fig. 1c, insulation of ice mandrels by insulation sheets was found to significantly reduce the rapid melting of ice and increase the cooling rate of both inner and outer surfaces of the tube; however, the production of ice mandrels with insulation sheets is time-consuming. Moreover, the strength of pure ice mandrels to full hardening the formed products in low compression ratios is still insufficient.

Fig. 8 Dimensions of designed mold to prepare ice billets

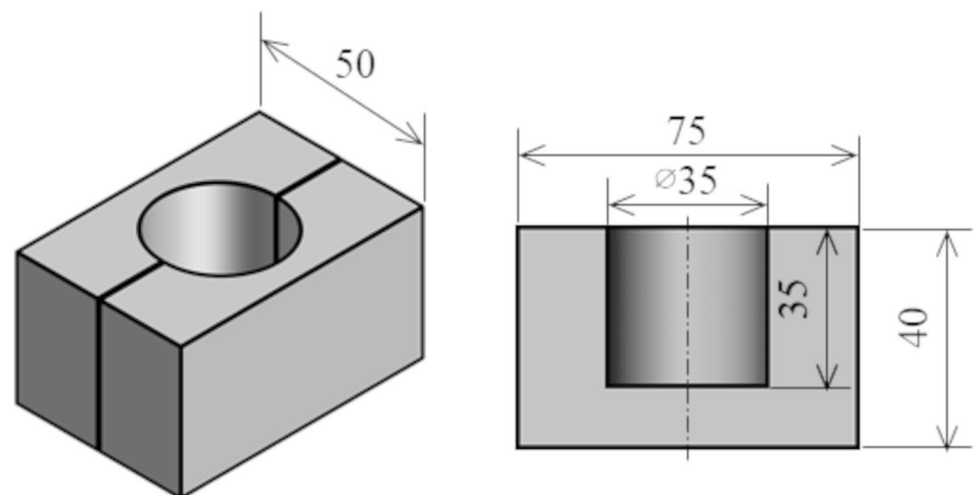
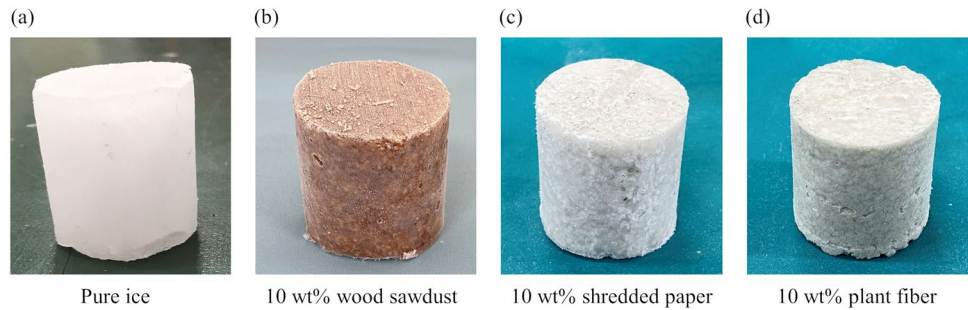
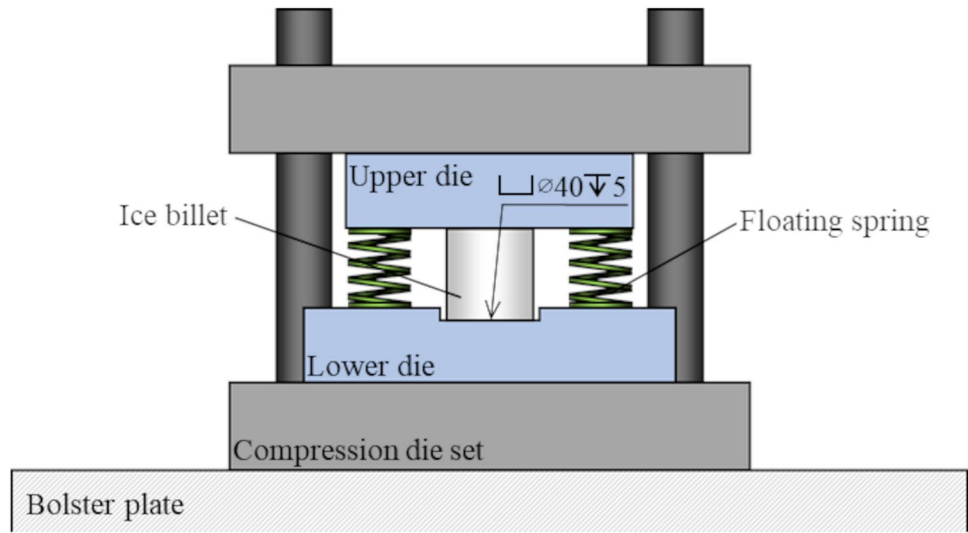

Fig. 9 Prepared ice billets for compression test**Fig. 10** A schematic of the compression tools

To further improve the strength of ice-based mandrels, composite ice mandrels have become attractive. “Pykrete” composite ice which produces by adding wood sawdust and water was proposed to improve the mechanical properties of ice, especially for construction structures [20, 21]. Moreover, the thermal conductivity of ice can be reduced by choosing fibers having lower thermal conductivity which leads to prevent rapid melting of the fiber-reinforced ice (FRI). Pure ice rapidly melts under pressure, while fiber-reinforced ice can withstand more pressure. Wu et al. [22] compared the strength of plain ice and fiber-reinforced ice under uniaxial compression. Lou et al. [23] proposed a shear constitutive model to predict the relationship between shear strength and deformation of fiber-reinforced ice by considering the influence of temperature and fiber content. Ohashi et al. [24] developed cold bending of steel tubes by a filling medium of fiber-reinforced ice to prevent buckling of the bent tubes. However, research on fiber-reinforced ice and its applications has not been conducted extensively. Therefore, to enhance the shape accuracy and quenching behavior in compression of ultra-high strength steel hollow products, the contact surface pressure between the

die and tube was significantly improved by increasing the required reaction force using fiber-reinforced ice mandrel as shown in Fig. 1d.

The procedure for hot stamping of an ultra-high strength hollow part using fiber-reinforced ice mandrel is shown in Fig. 2. First, a quenchable steel tube containing fiber-reinforced ice is clamped between copper electrodes, and both ends of the tube are sealed by ice stoppers to prevent the projection of fiber-reinforced ice during flattening. To apply not only rapid heating of fiber-reinforced ice-filled tube but also integrate the heating and stamping steps without the requirement for transferring, resistance heating is utilized. After the tube is heated to austenite temperature, the heated tube is immediately compressed and quenched in die simultaneously by holding at the bottom dead center of a press slide.

Table 3 Conditions utilized for the uniaxial compression test

Parameter	Value
Amount of compression [mm]	20
Compression speed [mm/s]	0.5

The selected reinforcements for ice mandrel should not only be eco-friendly and accessible but also requires air gaps to reduce the heat conductivity. Hence, three types of natural fiber-reinforcing materials consisting of wood sawdust (Japanese cedar with < 1 mm mesh size), shredded paper (copy paper, 67 g/m²), and plant fiber composed of recycled toilet paper were nominated as ice reinforcers. As it is illustrated in Fig. 3, the reinforcing material was shredded and evenly mixed with water (1:1 in weight) using a mixer to reach the target uniform distribution. Finally, the obtained composite material was filled in the tube and solidified in a commercial freezer at − 50 °C.

Figure 4 shows the microscopic view of the utilized fibers for fiber-reinforced ice mandrels. Long carbon and woven fibers are mainly employed to obtain the high strength of structure products; however, random short fibers are more suitable for ice mandrels due to the easy preparation and removal of fiber-reinforced ice mandrels from the formed products.

2.2 Procedures and conditions of hot stamping of tubes using fiber-reinforced ice mandrel and resistance heating

The designed setup for hot stamping of tubes using fiber-reinforced ice mandrel and resistance heating is illustrated in Fig. 5. A quenchable steel tube having the outer diameter, thickness, and length of 38.1 mm, 1.6 mm, and 140 mm was sandwiched between the copper electrodes under an average pressure of 2 MPa. The chemical composition of the as-received quenchable steel tube provided by the Nippon Steel Corporation Group is shown in Table 1. A DC power supply with a current density of 30 A/mm² (5.6 kA) was used to rapidly heat the tube by resistance heating. Moreover, to uniformly heat the tube and gain a uniform distribution in electrical contact resistance, the fitting between the tube and electrodes was increased by inserting tin-coated flat copper braids at the interface between them. The austenite transformation temperature (Ac3) of the as-received steel tube was approximately 820 °C, and thus, the tube was heated up to above 900 °C in 13.5 s. The resistance-heated tube was immediately held for 10 s at the bottom dead center of an 800 kN CNC servo press (Amada Co. Ltd, SDE-8018) under an average speed of 200 mm/s during stamping. The conditions utilized for hot stamping of tubes using fiber-reinforced ice mandrels are given in Table 2. Each experiment was performed three times to ensure acquired data repeatability, and the results were averaged.

In the preliminary experiments of the study, to thermally insulate the ice mandrel and reduce the heat transfer, three layers of insulation sheets are inserted between the tube and fiber-reinforced ice mandrel and is defined by ($n_p=3$). The

thickness and weight of each layer of thermal paper were 0.12 mm and 67.5 g/m², respectively. Consequently, due to the prevention of melting of ice by natural fibers, the insulation sheets were removed, and hot stamping of tubes using fiber-reinforced ice mandrels was performed without using insulation sheets ($n_p=0$).

The temperature distributions of the tubes with and without fiber reinforcements just after the end of resistance heating were measured by a two-color radiation thermography (Nobby Tech. Ltd., Thermera-NIR2) to omit the effect of the changing in surface emissivity by oxidation and are shown in Fig. 6. Utilization of the fiber-reinforced ice mandrel led to a more uniform temperature distribution on the surface of the tube compared with that of the pure ice mandrel.

Ultra-high strength steel hollow products were formed in both high and low compression conditions. A flat die that compressed the internal volume of the tube by 50% was utilized for high compression ratios and formed a flat cross-section, while a square die that hardly compressed the internal volume of the steel tube was designed for low compression ratios. The dies were made of carbon steel of S50C in JIS, and the details of the forming dies are shown in Fig. 7. Moreover, to prevent ice projection during high compression, both ends of the tubes were covered with steel sheets which are called ice stoppers.

3 Mechanical and thermal properties of natural fiber-reinforced ice

3.1 Uniaxial compression test of fiber-reinforced ice

To characterize the mechanical properties of fiber-reinforced ice mandrels, cylindrical billets of each type of ice mandrel were prepared, and uniaxial compression tests were conducted. The cylindrical billet having 35 mm in diameter and 35 mm in height was located on the lower plate and compressed by the upper plate using a cylindrical slide. The compressing distance of the samples was 20 mm.

The designed mold to prepare the billets is shown in Fig. 8. The split-type mold was made of carbon steel of S50C in JIS and had a cylindrical hole with a diameter and depth of 35 mm. To prepare the ice billet, first, the joint of the molds were sealed with clay, and a thin production film is wrapped around the side surface and the bottom surface of the hole. Subsequently, the prepared mandrel material is filled and frozen under the same conditions as the experiment. Finally, due to the expansion of the volume of the ice billet after freezing, the solidified billet is shaved, and the cylindrical billet with flat top and bottom surfaces is separated from the mold. The appearance of the fiber-reinforced ice billets is shown in Fig. 9.

Fig. 11 Compressed ice billets with and without fiber reinforcements after uniaxial compression test

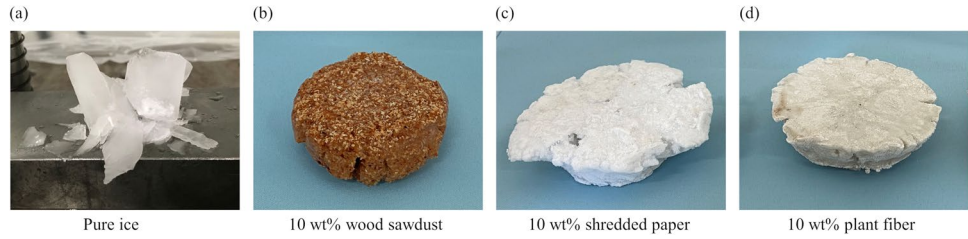
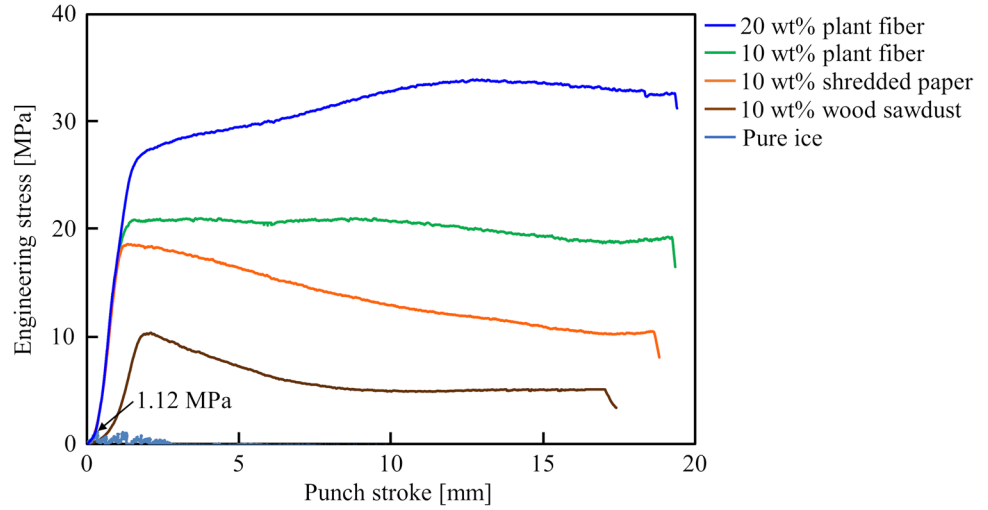

Fig. 12 Engineering stress–punch stroke curves of ice billets with and without fiber reinforcements



A schematic diagram of the compression tools and the appearance of the compression die set are shown in Fig. 10. A hydraulic servo press with a maximum capacity of 300 kN was utilized for uniaxial compression, and the displacement of the slide was measured by the displacement meter provided in the servo press, and the load was measured by a load cell and recorded by a data logger. The upper and lower dies were precooled to $-50\text{ }^{\circ}\text{C}$ (similar to the ice billet temperature) to

prevent ice melting due to the direct contact with the ice billet. The surface that compressed the lower portion of the billet is counterbored to 40 mm diameter and a depth of 5 mm to prevent the billet from ejection during compression. Moreover, to avoid pressurization and compression of the billet due to the weight of the tools during the installation stage, floating springs were set between the upper and lower dies.

Fig. 13 Engineering stress–punch stroke curves of 10 wt% plant fiber ice billets with different ice temperatures

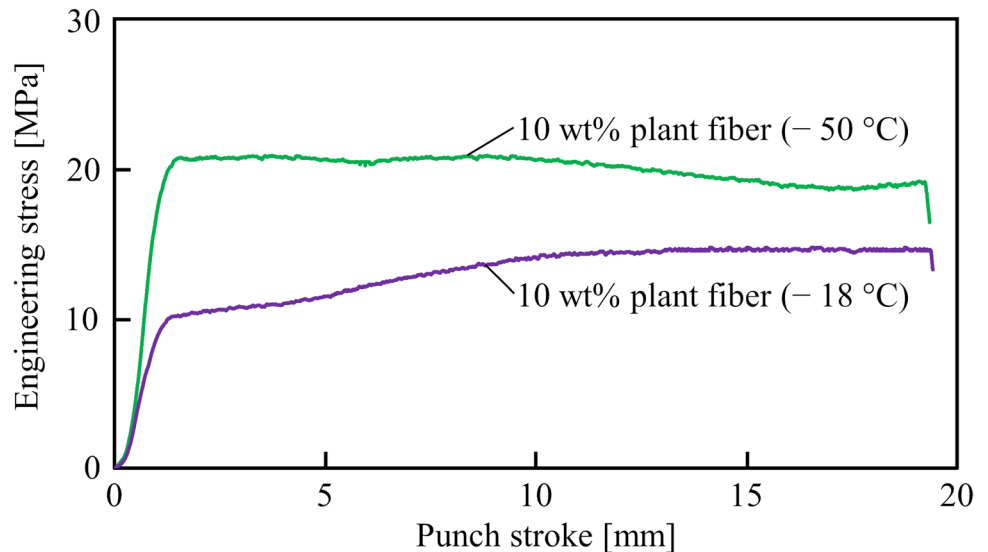

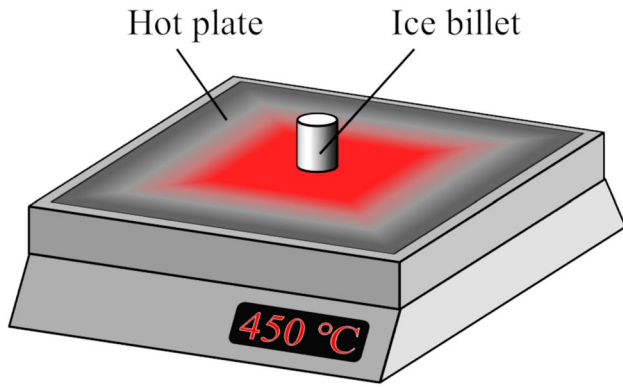

Fig. 14 A schematic of placement of ice billet on ceramic hot plate

The conditions utilized for the uniaxial compression test are presented in Table 3. The compressed billets after the uniaxial compression test are shown in Fig. 11. The results indicate that the ductility of the fiber-reinforced ice significantly improved compared with that of the pure ice billet, which was immediately broken after the start of the compression.

The engineering stress–punch stroke curves of the ice billets with and without fiber reinforcements are shown in Fig. 12. The ice billet without fiber reinforcements was immediately broken, while the compression load is largely influenced by the utilization of ice reinforcements. With the continuous increase of punch stroke, the compression load of the 10 wt% shredded paper decreased gradually. However, the plant fiber-reinforced ice was shown a more uniform and constant ductile behavior. Moreover, by increasing the fiber content to 20 wt%, the stress of the plant fiber-reinforced ice billet reached up to about 35 MPa.

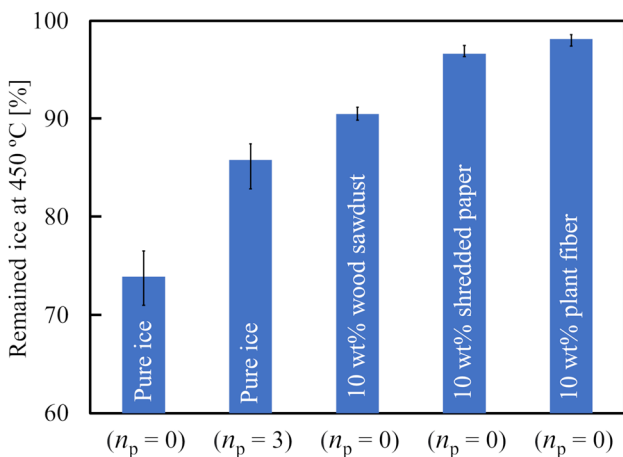

Fig. 15 Residual ice rate just after heating for various types of ice billets

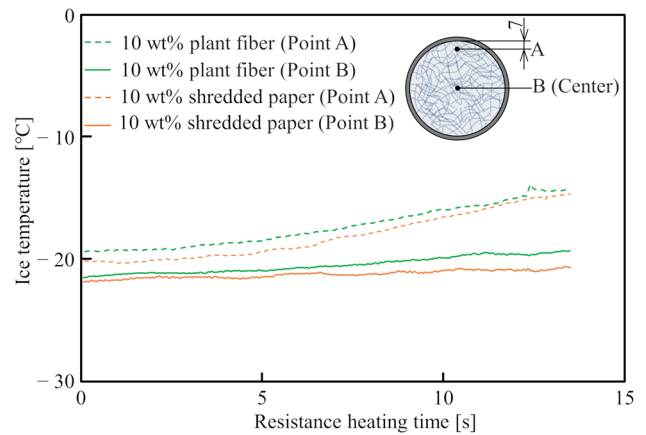

Fig. 16 Temperature changes of fiber-reinforced ice mandrels during resistance heating

To study the effect of the ice temperature on the uniaxial compression characteristics of ice mandrel, the 10 wt% plant fiber billets were frozen at different temperatures of $-18\text{ }^{\circ}\text{C}$ and $-50\text{ }^{\circ}\text{C}$. The results indicate that by decreasing the ice temperature, the stress of the ice remarkably increased as shown in Fig. 13. Although the type and content of fiber are different from the previous studies, the obtained results are found to be in good agreement with their findings [22, 23]. Therefore, by decreasing the ice temperature, a larger reaction force can be obtained by the fiber-reinforced ice.



Fig. 17 Hot-stamped tube using a 10 wt% shredded paper fiber-reinforced ice mandrel with three layers of insulation sheets ($n_p=3$) in flat dies

Fig. 18 Cross-sections of hot-stamped tubes using ice mandrel with and without fiber reinforcements in hoop direction with three layers of insulation sheets ($n_p=3$)

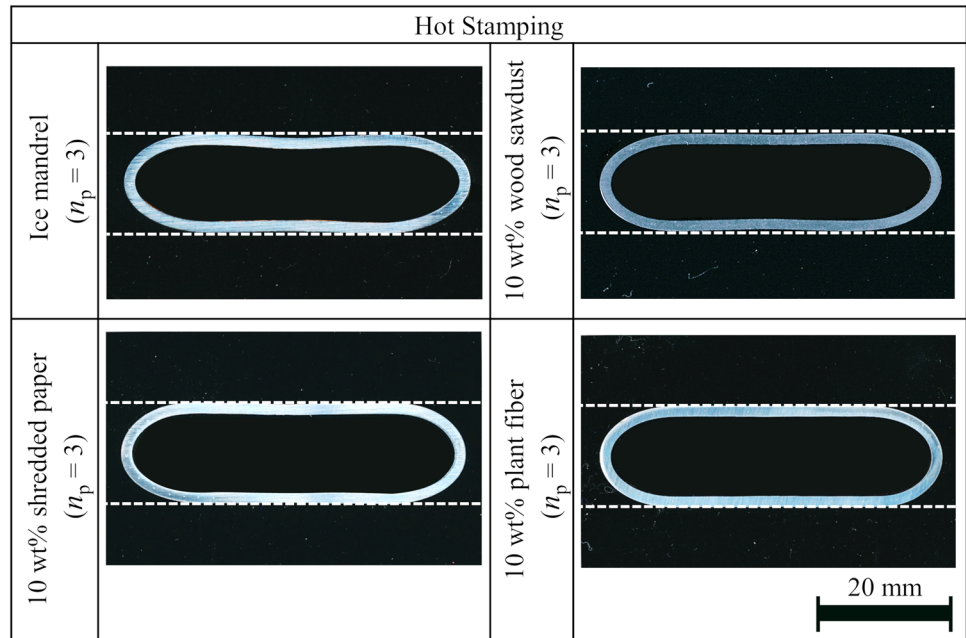

3.2 Thermal insulation of ice mandrels by fiber reinforcement

To investigate the melting behavior of ice mandrels at elevated temperatures, the ice billets were placed on a ceramic hot plate as shown in Fig. 14. The ice billets were put several times, and residual ice were measured. The temperature of the hot plate having a 250 mm \times 250 mm square area was adjusted to 450 $^{\circ}$ C to ensure homogeneous distribution of heat on ice billets, and the samples were set in the center of the hot plate for 13.5 s. To prevent the repeatable switching of the hot plate, the current was cut off just before each experiment. Subsequently, the mass of the remained ice was measured to determine the residual ice rate with respect to the mass of the initial ice mandrel before heating.

The residual rate of several types of ice mandrels just after the experiment is shown in Fig. 15. The pure ice mandrel immediately began to melt from its bottom portion, and evaporation occurred between the bottom side of the ice billet and hot plate. However, by attaching insulation sheets at the bottom of the pure ice billets, the melting was reduced compared with that without insulation sheets. In the case of utilizing wood sawdust fibers, the melted water led to not obtain the sufficient reaction force. Consequently, shredded paper and plant fiber-reinforced ice mandrels showed obvious superiority with excellent thermal insulation performance and thermal stability even without the requirement of insulation sheets due to the absorption of the slightly melted water by fibers. The residual ice by utilizing shredded paper and plant fiber-reinforced ice mandrels were approximately 25% higher than that of pure ice mandrel. Therefore, the insulation sheets to prevent

melting of the natural fiber-reinforced ice billets can be omitted, and it led to easy preparation of fiber-reinforced ice mandrels.

To measure the temperature changes of fiber-reinforced ice mandrels during resistance heating, K-type thermocouples were embedded in the specified distance of fiber-reinforced ice mandrels and subsequently were frozen with the ice-filled tubes. It should be noted that the difference between the initial temperatures of the thermocouples embedded fiber-reinforced ice samples and main experiments was generally related to the required time for setting up this measurement test; therefore, the heating was started at about -20 $^{\circ}$ C. The temperature changes of the fiber-reinforced ice mandrels during resistance heating are shown in

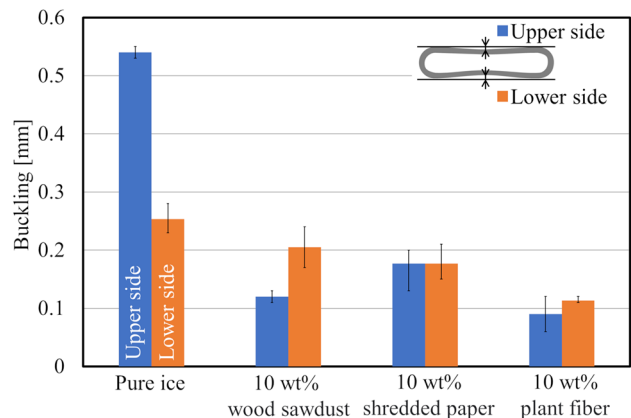

Fig. 19 Comparison of buckling depth of hot-stamped tubes using ice mandrels with and without fiber reinforcements with three layers of insulation sheets ($n_p=3$)

Fig. 20 Cross-sections of hot-stamped tubes using fiber-reinforced ice mandrels with and without insulation sheets

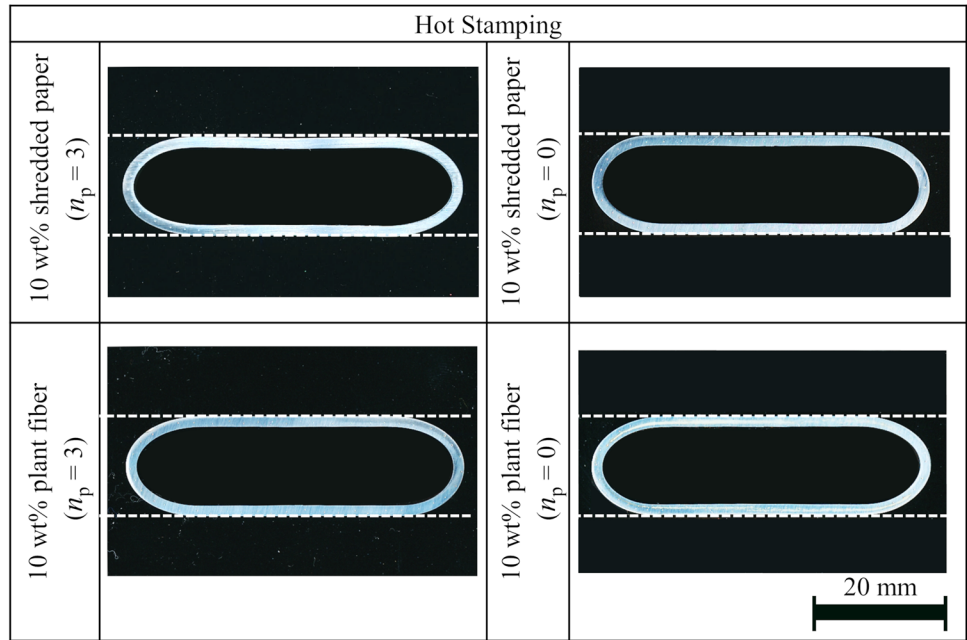

Fig. 21 Comparison of buckling depth of hot-stamped tubes using fiber-reinforced ice mandrels with and without insulation sheets

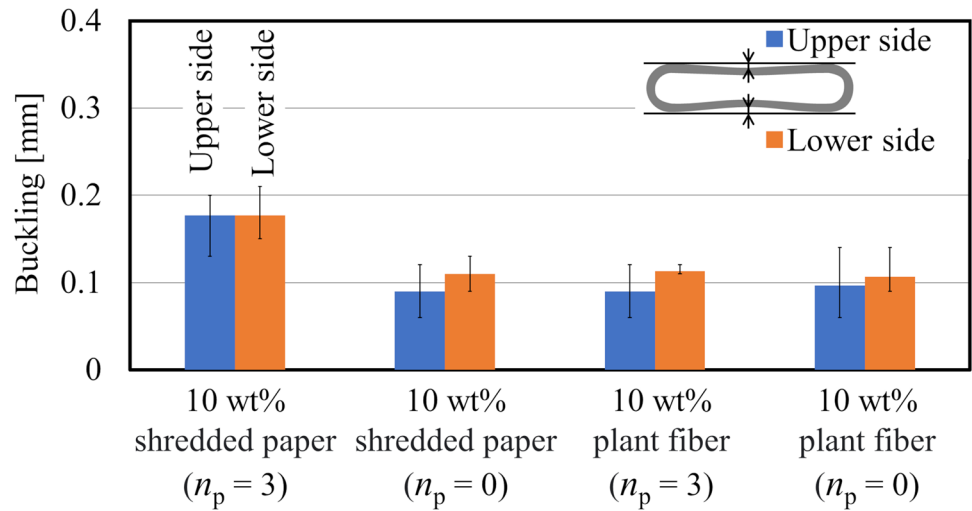

Fig. 22 Remained fibers at the center of hot-stamped tubes by twice tapping the tubes after experiments: **a** with 10 wt% shredded paper and **b** 10 wt% plant fiber

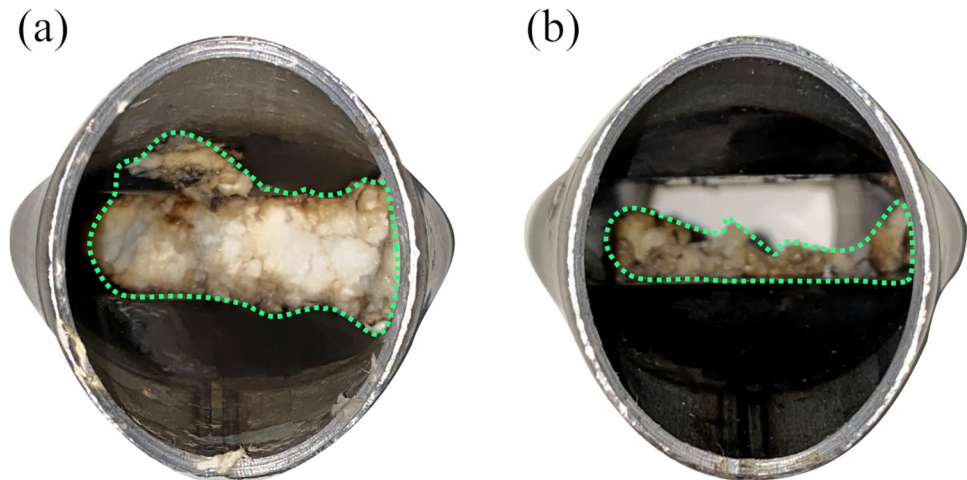

Fig. 16. The temperature of the outer portion of the fiber-reinforced ice mandrel which is measured at a distance of 7 mm from the inner surface of the tube (point A) gradually increased; however, the temperature of the center portion of the fiber-reinforced ice mandrel (point B) was approximately constant for fiber-reinforced ice mandrels. Therefore, decreasing the installation and heating time can cause an increase in the generated reaction force by ice.

4 Influence of fiber materials on forming behavior of hot-stamped tubes in high and low compression ratios

The hot-stamped tube using a 10 wt% shredded paper fiber-reinforced ice mandrel in flat dies is shown in Fig. 17. The cross-sections of the central portion of the hot-stamped tubes using ice mandrels with and without fiber reinforcements are shown in Fig. 18. The results indicate that by using fiber-reinforced ice mandrel, a clear reduction in buckling can be observed as compared with that of a pure ice mandrel.

The buckling depth of the hot-stamped tubes was measured by a laser profile measurement, and the comparison between the buckling depth of the hot-stamped tubes by ice mandrels with and without fiber reinforcements and three layers of insulation sheets ($n_p=3$) is shown in Fig. 19. Compared to the pure ice mandrel, the use of the fiber-reinforced ice mandrel showed a significant reduction in buckling depth. In the case of the utilization of pure ice mandrel, the slight melting of the ice led to a change in the temperature distribution of the upper and lower portion of the tube. Therefore, the deformation tends to occur on the upper portion due to high temperature. Consequently, it can be confirmed that fiber-reinforced ice mandrels were able to provide a large reaction force and improved the shape accuracy of hollow products.

As it was previously shown in Fig. 15, the melting of ice mandrel was suppressed even without the utilization of insulation sheets. Moreover, omitting the insulation sheets allowed an easier preparation of the fiber-reinforced ice mandrels. Therefore, in order to compare the forming results, the hot stamping of tubes using fiber-reinforced ice mandrels was performed without insulation sheets.

The cross-sections and buckling depth of the hot-stamped tubes using fiber-reinforced ice mandrels with and without insulation sheets are shown in Figs. 20 and 21, respectively. The results indicate that the cross-sections and buckling depth of the formed tubes without insulation sheets are almost the same as the formed tubes with three layers of insulation sheets. However, in the case of utilization of the 10 wt% shredded paper with insulation sheets, the soft insulation sheets acted as a cushion and led to generate a gap between the fiber-reinforced ice mandrel and tube.

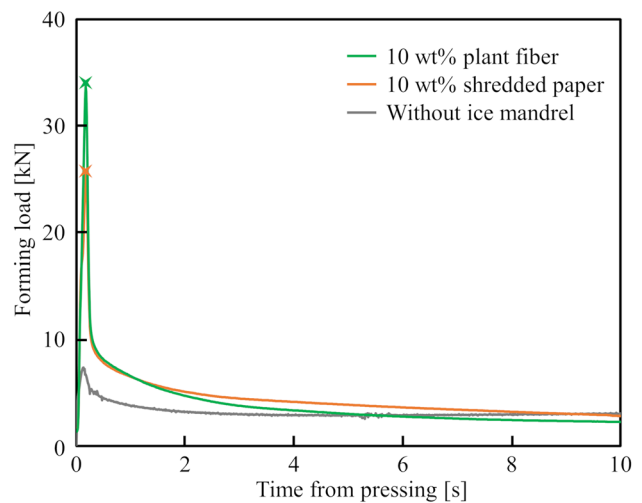

Fig. 23 Forming load histories of the tubes formed by fiber-reinforced ice mandrels without insulation sheets ($n_p=0$)

Therefore, buckling depth tended to slightly increase due to the generated gap.

Moreover, utilizing plant fiber as a reinforcement material led to not only further prevention of buckling but also easy removal of fiber-reinforced ice mandrel from the formed tube compared with that of shredded paper as shown in Fig. 22.

The forming load histories of the hot-stamped tubes by fiber-reinforced ice mandrels without using insulation sheets ($n_p=0$) are shown in Fig. 23. The maximum forming loads of tubes by 10 wt% shredded paper and 10 wt% plant fiber

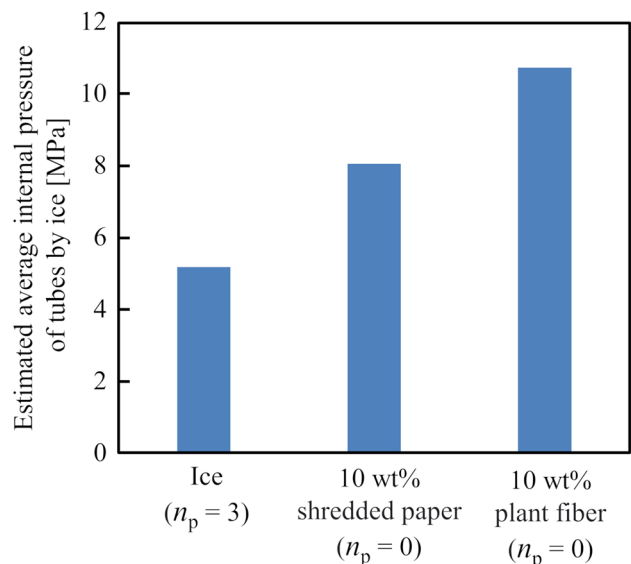
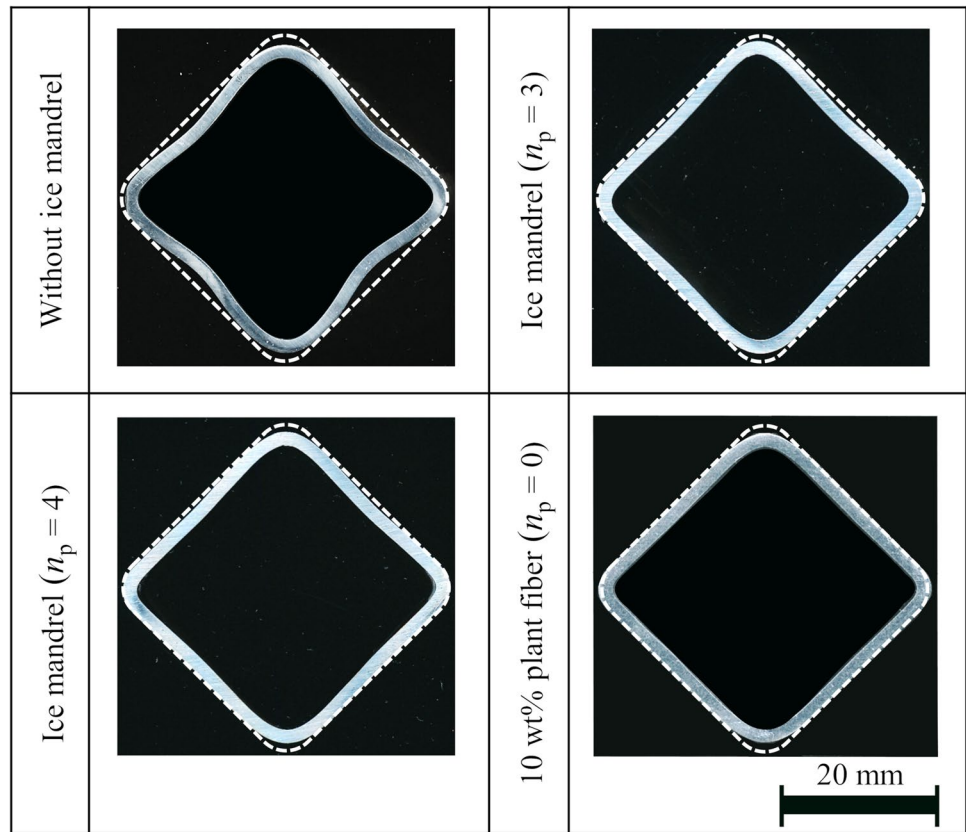

Fig. 24 Estimated internal pressure of tubes with and without fiber reinforcements for flat dies by using ice stoppers

Fig. 25 Cross-sections of hot-stamped tubes using ice mandrel with and without fiber reinforcements in hoop direction in low compression ratios by square die



are 25.4 kN and 33.7 kN, respectively. It can be inferred that by utilizing a 10 wt% plant fiber, a larger reaction force can generate by the compression of the ice, which led to further reduction of buckling and improvement of the contact surface pressure with the die during quenching. However, the forming load dropped sharply after reaching its maximum value. Therefore, it can be concluded that by gradually decreasing the pressing speed, the rapid force drop during pressing can be reduced, and the die quenching of tubes improved.

The estimated internal pressure generated by ice with and without fiber reinforcements estimated from the forming force is shown in Fig. 24. To calculate the estimated internal pressure, the maximum load of formed tubes with ice mandrels was subtracted from that of without ice mandrels and subsequently was divided by projected compressed area. By utilizing the fiber-reinforced ice, the maximum internal pressure of tubes reached up to above 10 MPa which led to a further decrease in the buckling of hot-stamped tubes.

Since the fiber-reinforced ice mandrel increases the generated reaction force, hot stamping of tubes using the fiber-reinforced ice mandrel was also performed in low compression conditions by using square dies. The cross-sections and buckling depth of the hot-stamped tubes in low compression ratios with and without fiber reinforcements are shown in Figs. 25 and 26, respectively. The results indicate that utilization of the fiber-reinforced ice mandrel improved the

contact pressure between the die and tube by further preventing buckling. Therefore, 10 wt% plant fiber can significantly improve the shape accuracy and lead to obtaining buckling-free flat portions in both upper and lower sides even in low compression ratios by square dies.

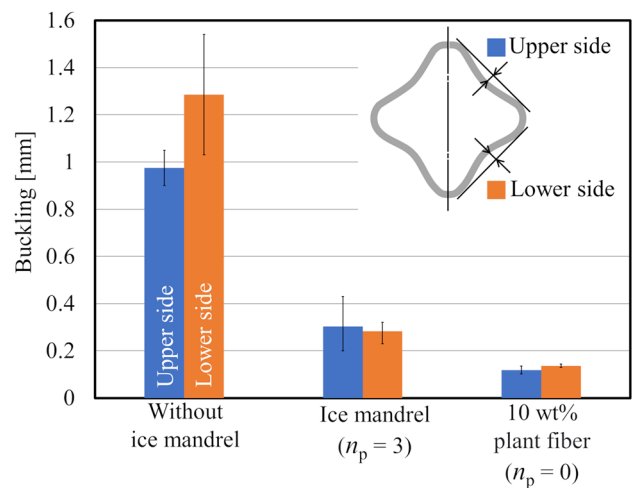

Fig. 26 Comparison of buckling depth of hot-stamped tubes using ice mandrels with and without fiber reinforcements in low compression ratios by square die

Fig. 27 Vickers hardness distributions of hot-stamped tubes using fiber-reinforced ice mandrels in flat dies in hoop direction of center of tube

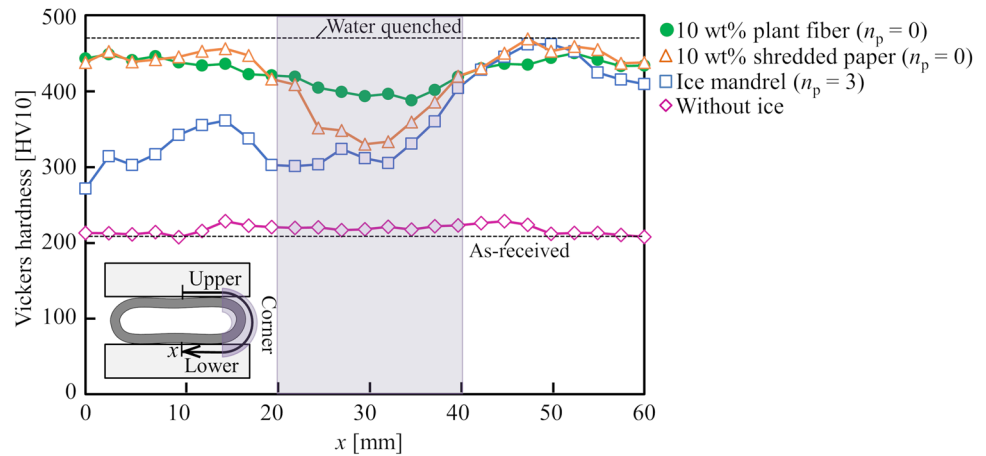
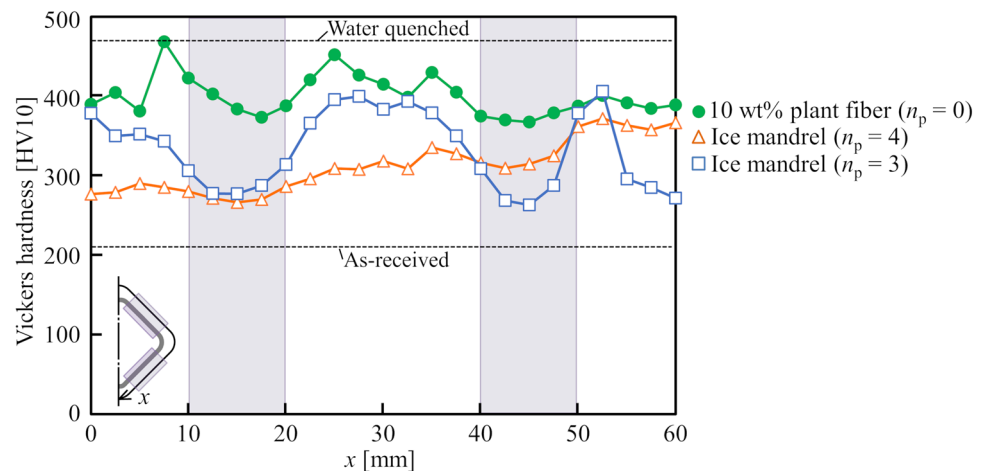

Fig. 28 Vickers hardness distributions of hot-stamped tubes with and without fiber reinforcements for ice mandrels in square dies in hoop direction of center of tube



5 Influence of fiber materials on hardness distribution of hot-stamped tubes

The Vickers hardness distributions of the hot-stamped tubes with and without fiber reinforcements are shown in Fig. 27. The Vickers hardness significantly increased by utilizing the fiber-reinforced ice mandrels compared with the pure ice mandrel. By utilizing 10 wt% plant fibers, the hardness of both the upper surface and lower surface of the tube raised to almost 450 HV10. Moreover, the decrease in hardenability of the tube even in the corners that did not come into contact with the dies was small, and the hardness above 400 HV10 was obtained in the corners as well without the requirement of cooling channels for tools.

In the case of utilization of pure ice mandrel, quenching of tube in square dies is still insufficient due to the low compression ratios. The Vickers hardness distributions of the central portion of the hot-stamped tubes with and

without fiber reinforcements for ice mandrels in square dies are illustrated in Fig. 28. It is found that a 10 wt% plant fiber can remarkably enhance the quenching of the hot-stamped tube by not only generating a sufficient reaction force but also facilitating rapid cooling by ice. Therefore, full-hardened hot-stamped tubes can be obtained by inserting fiber-reinforced ice mandrels in low compression ratios without the change in the internal volume of the tube.

6 Conclusion

To enhance the shape accuracy and quenchability in forming processes of hollow products in high and low compression ratios, a natural composite ice mandrel was developed and utilized in hot stamping of steel tubes. By adding fiber reinforcements to the pure ice, the melting of the ice is greatly prevented, and the generated

reaction force from the ice mandrel was increased. The fiber-reinforced ice mandrels significantly improved the shape accuracy and die quenching of tubes without the requirement of thermal insulation sheets. The fiber-reinforced ice mandrels displayed certain ductility compared with the brittle pure ice mandrel. However, the shredded paper and plant fibers were considered more advantageous than the wood fiber due to their excellent water absorption capabilities. The estimated maximum internal pressure of tubes using fiber-reinforced ice mandrels was increased about twice compared with pure ice mandrels. Finally, the strength of the formed hollow products in both high and low compression ratios was heightened by increasing the hardness to above 400 HV10 even in the portions not in contact with dies without the requirement of cooling channels for tools.

The benefits mentioned above are not the only advantages gained by the utilization of fiber-reinforced ice in industrial applications. However, the performance of various types of fiber reinforcers, optimization of fiber length, and reusability of the mandrels are essential to fulfill the requirement of mass production. Moreover, as the generated force by fiber-reinforced ice mandrel is high, it can be used not only in compression processes but also in other applications of forming processes of sheets and tubes such as bulging and bending.

Author contribution Ali Talebi-Anaraki: investigation, conceptualization, methodology, data curation, validation, visualization, writing—original draft, writing—review and editing. Tomoyoshi Maeno: investigation, conceptualization, supervision, project administration, funding acquisition, writing—review and editing. Yuta Matsubara: investigation. Ryohei Ikeda: investigation. Ken-ichiro Mori: investigation, funding acquisition, writing—review and editing. All authors have read and given approval to the final version of the manuscript.

Funding Open access funding provided by Yokohama National University. This work was supported by JSPS KAKENHI Grant-in-Aid for Scientific Research (B) of Number JP18H01749.

Declarations

Competing interests The authors declare no competing interests.

Open Access This article is licensed under a Creative Commons Attribution 4.0 International License, which permits use, sharing, adaptation, distribution and reproduction in any medium or format, as long as you give appropriate credit to the original author(s) and the source, provide a link to the Creative Commons licence, and indicate if changes were made. The images or other third party material in this article are included in the article's Creative Commons licence, unless indicated otherwise in a credit line to the material. If material is not included in the article's Creative Commons licence and your intended use is not permitted by statutory regulation or exceeds the permitted use, you will need to obtain permission directly from the copyright holder. To view a copy of this licence, visit <http://creativecommons.org/licenses/by/4.0/>.

References

1. Maeno T, Mori K-I, Sakagami M, Nakao Y, Talebi-Anaraki A (2020) Minimisation of heating time for full hardening in hot stamping using direct resistance heating. *J Manuf Mater Process* 4(3):80. <https://doi.org/10.3390/jmmp4030080>
2. Maeno T, Mori K-I, Homma H, Talebi-Anaraki A, Ikeda R (2021) Corner strengthening by local thickening and ausforming using planar compression in hot stamping of ultra-high strength steel parts. *Metals* 11:1977. <https://doi.org/10.3390/met11121977>
3. Mori K, Bariani PF, Behrens BA, Brosius A, Bruschi S, Maeno T, Merklein M, Yanagimoto J (2017) Hot stamping of ultra-high strength steel parts. *CIRP Ann* 66(2):755–777. <https://doi.org/10.1016/j.cirp.2017.05.007>
4. Alaswad A, Benyounis KY, Olabi AG (2012) Tube hydroforming process: a reference guide. *Mater Des* 33:328–339. <https://doi.org/10.1016/j.matdes.2011.07.052>
5. Nikhare C, Weiss M, Hodgson PD (2017) Buckling in low pressure tube hydroforming. *J Manuf Process* 28:1–10. <https://doi.org/10.1016/j.jmapro.2017.05.015>
6. Zheng K, Politis DJ, Wang L, Lin J (2018) A review on forming techniques for manufacturing lightweight complex-shaped aluminium panel components. *Int J Lightweight Mater Manuf* 1(2):55–80. <https://doi.org/10.1016/j.ijlmm.2018.03.006>
7. Talebi-Anaraki A, Chougan M, Loh-Mousavi M, Maeno T (2020) Hot gas forming of aluminum alloy tubes using flame heating. *J Manuf Mater Process* 4(2):56. <https://doi.org/10.3390/jmmp4020056>
8. Talebi-Anaraki A, Loh-Mousavi M, Wang L-L (2018) Experimental and numerical investigation of the influence of pulsating pressure on hot tube gas forming using oscillating heating. *Int J Adv Manuf Technol* 97:3839–3848. <https://doi.org/10.1007/s00170-018-2228-y>
9. Neugebauer R, Schieck F, Werner M (2011) Tube press hardening for light weight design. Proceedings of the ASME international manufacturing science and engineering conference, Corvallis, USA, pp 495–502
10. Talebi-Anaraki A, Maeno T, Matsubara Y, Ikeda R, Mori K (2022) Integration of hot tube gas forming and die quenching of ultra-high strength steel hollow parts using low pressure sealed-air. *Materials* 15:1322. <https://doi.org/10.3390/ma15041322>
11. Grüner M, Gnihl T, Merklein M (2014) Blank hydroforming using granular material as medium- investigations on leakage. *Procedia Eng* 81(11):1035–1042. <https://doi.org/10.1016/j.proeng.2014.10.137>
12. Chen H, Hess S, Haeberle J, Pitikaris S, Born P, Güner A, Sperl M, Tekkaya AE (2016) Enhanced granular medium-based tube and hollow profile press hardening. *CIRP Ann* 65(1):273–276. <https://doi.org/10.1016/j.cirp.2016.04.010>
13. Grüner M, Merklein M (2011) Influences on the molding in hydroforming using granular material as a medium, The 8th International Conference and Workshop on Numerical Simulation of 3D Sheet Metal Forming Processes (NUMISHEET 2011). AIP Conference Proceedings, Volume 1383, pp 645–652. <https://doi.org/10.1063/1.3623668>
14. Yang ZY, Zhao CC, Dong GJ, Du B, Zhang L (2018) Analytical model of corner filling with granular media to investigate the friction effect between tube and media. *Int J Adv Manuf Technol* 99:211–224. <https://doi.org/10.1007/s00170-018-2429-4>
15. Chen H, Güner A, Khalifa NB, Tekkaya AE (2016) Granular media-based tube press hardening. *J Mater Process Technol* 228:145–159. <https://doi.org/10.1016/j.jmatprotec.2015.03.028>
16. Talebi-Anaraki A, Maeno T, Ikeda R, Morishita K, Mori KK (2021) Quenchability improvement and control simplification by ice mandrel in hot stamping of ultra-high strength steel hollow parts.

- J Manuf Process 64:916–926. <https://doi.org/10.1016/j.jmapro.2021.02.037>
17. Morgan P (2005) Carbon fibers and their composites. CRC Press, Boca Raton
 18. Verma D, Sharma S (2017) Green biocomposites: a prospective utilization in automobile industry, Green Biocompos Des Appl 167–191
 19. Nakamura N, Mori K-I, Abe Y (2020) Applicability of plastic tools additively manufactured by fused deposition modelling for sheet metal forming. Int J Adv Manuf Technol 108:975–985. <https://doi.org/10.1007/s00170-019-04590-5>
 20. Vasiliev NK (1993) On development of fibre-ice-composites. Cold Reg Sci Technol 21(2):195–199. [https://doi.org/10.1016/0165-232X\(93\)90007-U](https://doi.org/10.1016/0165-232X(93)90007-U)
 21. Vasiliev NK, Pronk ADC, Shatalina IN, Janssen FHME, Houben RWG (2015) A review on the development of reinforced ice for use as a building material in cold regions. Cold Reg Sci Technol 115:56–63. <https://doi.org/10.1016/j.coldregions.2015.03.006>
 22. Wu Y, Lou X, Liu X, Pronk A (2020) The property of fiber reinforced ice under uniaxial compression. Mater Struct 53(2):1–15. <https://doi.org/10.1617/s11527-020-01463-2>
 23. Lou X, Wu Y (2022) Influence of temperature and fiber content on direct shear properties of plain ice and fiber-reinforced ice. Cold Reg Sci Technol 194:103458. <https://doi.org/10.1016/j.coldregions.2021.103458>
 24. Ohashi T (2016) Steel tube bending with a filling medium of fiber-reinforced ice (FRI). Key Eng Mater 703:11–16. <https://doi.org/10.4028/www.scientific.net/KEM.703.11>

Publisher's note Springer Nature remains neutral with regard to jurisdictional claims in published maps and institutional affiliations.